



Selection: Open Screw Compressors OS

Input Values

Compressor model	OSK7471-K	Speed	2900 /min
Refrigerant	R404A	Useful superheat	100%
Reference temperature	Dew point temp.	Additional cooling	Automatic
Liq. subc. (in condenser)	0 K	Max. discharge gas temp.	80,0 °C
Suct. gas superheat	10,00 K	Cooling capacity	100 %
Operating mode	Standard		

Result

Q [W]	Cooling capacity	Qac [kW]	Additional cooling
P [kW]	Power input	tcu [°C]	Liquid temp.
COP [-]	COP/EER	pm [bar(a)]	ECO pressure
mLP [kg/h]	Mass flow LP	Qsc [kW]	sub cooler capacity (ECO)
mHP [kg/h]	Mass flow HP		

tc	to	10°C	5°C	0°C	-5°C	-10°C	-15°C	-20°C	-25°C
30°C	Q [W]	--	308730	257468	213221	175197	142678	115029	--
	P [kW]	--	50,6	49,1	47,6	46,2	45,0	43,9	--
	COP [-]	--	6,10	5,24	4,48	3,79	3,17	2,62	--
	mLP [kg/h]	--	8255	7028	5948	4999	4169	3445	--
	mHP [kg/h]	--	8255	7028	5948	4999	4169	3445	--
	Qac [kW]	--	--	--	--	--	--	--	--
	tcu [°C]	--	29,6	29,6	29,6	29,6	29,6	29,6	--
	pm [bar(a)]	--	--	--	--	--	--	--	--
	Qsc [kW]	--	--	--	--	--	--	--	--
40°C	Q [W]	--	268610	222923	183593	149893	121170	96838	--
	P [kW]	--	60,3	58,8	57,4	56,1	54,8	53,7	--
	COP [-]	--	4,45	3,79	3,20	2,67	2,21	1,80	--
	mLP [kg/h]	--	8161	6934	5853	4904	4074	3350	--
	mHP [kg/h]	--	8161	6934	5853	4904	4074	3350	--
	Qac [kW]	--	--	--	--	--	--	--	--
	tcu [°C]	--	39,6	39,6	39,6	39,6	39,6	39,6	--
	pm [bar(a)]	--	--	--	--	--	--	--	--
	Qsc [kW]	--	--	--	--	--	--	--	--
50°C	Q [W]	--	223087	183804	150098	121325	96900	76305	--
	P [kW]	--	72,1	70,8	69,5	68,3	67,0	65,8	--
	COP [-]	--	3,09	2,60	2,16	1,78	1,45	1,16	--
	mLP [kg/h]	--	7944	6729	5657	4715	3890	3169	--
	mHP [kg/h]	--	7944	6729	5657	4715	3890	3169	--
	Qac [kW]	--	--	--	--	--	5,27	12,88	--
	tcu [°C]	--	49,7	49,7	49,7	49,7	49,7	49,7	--
	pm [bar(a)]	--	--	--	--	--	--	--	--
	Qsc [kW]	--	--	--	--	--	--	--	--

-- No calculation possible (see message in single point selection)

*According to EN12900 (10K suction gas superheat, 0K liquid subcooling)

Application Limits Standard OSK7471

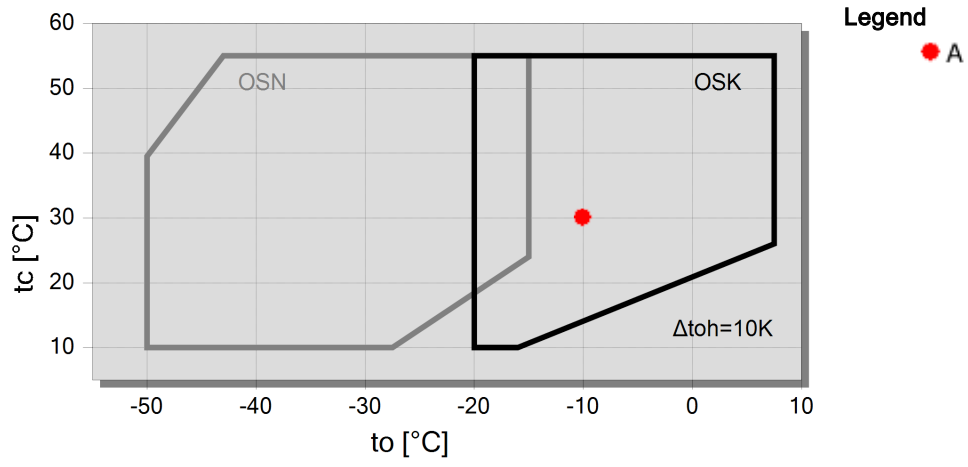



Technical Data: OSK7471-K

Dimensions and Connections

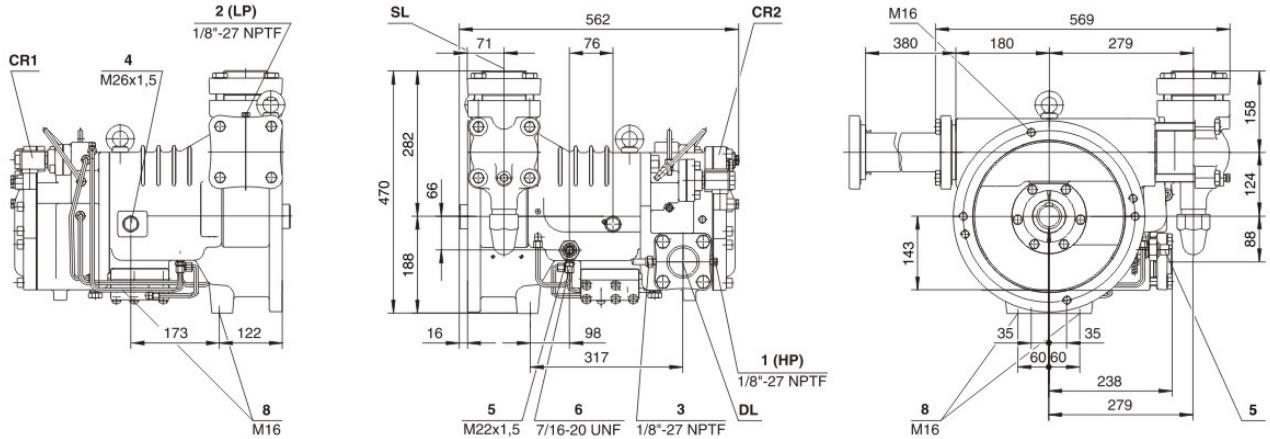

Technical Data

Technical Data

Displacement (2900 RPM 50 Hz)	250 m ³ /h
Displacement (3500 RPM 60 Hz)	302 m ³ /h
Allowed speed range	1450 .. 4000 min ⁻¹
Sens of rotation (compressor)	links / counter-clockwise
Weight	188 kg
Max. pressure (LP/HP)	19 / 28 bar
Connection suction line	76 mm - 3 1/8"
Connection suction line (NH3)	DN 80
Connection discharge line	54 mm - 2 1/8"
Connection discharge line (NH3)	DN 50
Oil type R22	B150SH, B100 (Option)
Oil type R134a/R404A/R507A/R407A/R407F	BSE170 (Option)

Extent of delivery (Standard)

Suction shut-off valve	Standard
Pressure relief valve	Standard
Check valve	Standard
Oil injection kit	Standard
Built in oil filter	Standard
discharge gas temperature monitoring	SE-B2
Discharge gas temperature sensor	Standard
Start unloading	Standard
Capacity control	100-75-50% (Standard)
Sight glass	Standard
Protective charge	Standard

Available Options

Oil flow control	Option
Discharge shut-off valve	Option
ECO connection with shut-off valve	Option
Adapter/shut-off valve for ECO	22 mm - 7/8" (Option)
Coupling housing	Option



Open Screw Compressors OS

OSK = Application for air-conditioning and medium temperature cooling.

OSN = Application for low temperature cooling.

OSH = Application for air-conditioning and heat pumps.

Notes regarding application limits (see "T.Data - Limits")

* Ranges are valid for standart operation and at full-load conditions.

* With high pressure conditions, part-laod operation is partly limited (see application limits in applications manual SH-500/SH-510).

* With Economizer operation the maximum admissible evaporation temperature is shifted by 10K downward (otherwise there is a danger of excessive compression and overlaod of the motor because of a higher mass flow). At pull-down conditions from higher evaporation temperatures, the ECO injection must remain closed until the evaporation temperature is below the maximum admissible value and a stable operation is achieved (e.g. control of the ECO solenoid valve by means of a low pressure cut-out). The use of the ECO-System with higher evaporation temperatures requires individual consultation with Bitzer.

OS53..OS74

* Capacity control with ECO operation at the same time is limited to one single regulating step (CR 75%). At CR 50% the ECO injection should be closed.

* Combined operation (ECO + CR 50%) is possible under certain conditions, control and system design, however, require individual consultation with Bitzer.

Motor Selection

The required driving motor is selected for starting conditions at direct start as well as at star-delta-start with start unloading (50% capcaity regulation). The starting conditions refer to the following defined operation points resp. to the maximum application limit of the compressor. Should the evaporation- or the condensing temperature of the plant be higher at the start, an individual motor selection is necessary.

Evaporation temperature for motor selection				
	HH	H	M	L
R134a	+20 °C	+12,5 °C	-5 °C	
R404A / R507A		+7,5 °C	-5 °C	-15 °C
R22		+12,5 °C	-5 °C	-10 °C
R407C		+12,5 °C	-5 °C	
NH ₃	+25 °C	+12,5 °C	-5 °C	-10 °C

The stated motor data refer to IEC motors at which the pull-up torque should not fall below 90% of the max. torque. In addition the following starting torque (referring to direct start) must be reached:

* open screw compressors 120%

Should the motor not fulfil these criteria, an individual selection is also necessary.

Lubricants and additional cooling for NH3 applications

	Type	Viscosity	Discharge gas (°C)	Oil injection (°C)
Reniso KM32	MO	32	ca. 60 .. max. 100	max. 50
Reniso KS46	MO	46	ca. 60 .. max. 80 (100 [1])	max. 60
Reniso KC68	MO	68	ca. 60 .. max. 80 (100 [1])	max. 60
Reflo 68A	MO (HT)	58	ca. 60 .. max. 80 (100 [1])	max. 60
SHC226E	PAO	68	ca. 60 .. max. 80 (100 [1])	max. 60

[1] 100 °C only after consultation with BITZER

Further information on the selection of lubricants can be found in the Application Manuals SH-500 and SH-510.

**Legend of connection positions according to "Dimensions":**

- 1 High pressure connection (HP)
 - 1a Additional high pressure connection
 - 1b Connection for high pressure transmitter (HP)
 - 2 Low pressure connection (LP)
 - 2a Additional low pressure transmitter (LP)
 - 2b Connection for low pressure transmitter (LP)
 - 3 Discharge gas temperature sensor connection (HP)
 - 4 Connection for economiser (ECO)
 - HS.85: ECO valve with connection pipe (option)
 - HS.95, OS.85, OS.95: ECO valve (option)
 - 5 Oil injection connection
 - 6 Oil pressure connection for HS.85 and OS.85:
Oil drain (compressor housing)
 - 7 Oil drain (motor housing)
 - 7a Oil drain (suction gas filter)
 - 7b Oil drain out of shaft seal (maintenance connection)
 - 7c Oil drain tube (shaft seal)
 - 8 Threaded bore for foot fastening
 - 9 Threaded bore for pipe support (ECO and LI line)
 - 10 Maintenance connection (oil filter)
 - 11 Oil drain (oil filter)
 - 12 Monitoring of oil stop valve
 - OS.85: Monitoring rotation direction and oil stop valve
 - 13 Oil filter monitoring
 - 14 Oil flow switch
 - 15 Earth screw for housing
 - 16 Pressure relief (oil filter chamber)
 - 17 Maintenance connection for shaft seal
 - 18 Liquid injection (LI)
 - 19 Compressor module
 - 20 Slider position indicator
 - 21 Oil level switch
 - 22 Connection for oil pressure transmitter
 - 23 Connection for oil and gas return
(for systems with flooded evaporator adaptor optional)
 - 24 Access to oil circulation restrictor
 - SL Suction gas line
 - DL Discharge gas line
- Dimensions can show tolerances according to EN ISO 13920-B.